



namri

sme



MSEC 2014

ASME International Manufacturing Science
and Engineering Conference

NAMRC 42

NAMRI/SME North American Manufacturing
Research Conference

ICM&P 2014

JSME International Conference on
Materials and Processing

JUNE 9-13, 2014

DETROIT, MICHIGAN USA

MSEC 2014ASME International
Manufacturing Science and
Engineering Conference**NAMRC 42**NAMRI/SME North American
Manufacturing Research
Conference**ICM&P 2014**JSME International
Conference on Materials
& Processing**JUNE 9-13, 2014** **DETROIT, MICHIGAN USA****Welcome**

As the President of the JSME Materials and Processing Division, President of SME NAMRI and the Chair of the ASME Manufacturing Engineering Division, we would like to welcome the co-located ASME International Manufacturing Science and Engineering Conference (MSEC), the SME North American Manufacturing Research Conference (NAMRC), and the JSME International Conference on Materials and Processing (ICMP). This is the second time that these three conferences have been co-located, the fourth time that MSEC and NAMRC have been co-located, and the third time that MSEC and ICMP have been co-located. So as is evident, there is a rich history with these conference collaborations which continue to grow. We are very fortunate to be in downtown Detroit, Michigan and having our conference joint with two other exceptional SME events, RAPID and the BigM. We truly appreciate the efforts of Professors Albert Shih, Kira Barton, and Chinedum Okwudire, and others at the University of Michigan for hosting us and bringing all of the conferences together. Another special acknowledgement is required for Seiichi Hata, John Ziegert, Ihab Ragai, and Gracious Ngaile who are the technical program chairs for the three conferences. A quality event of this size and stature does not happen without considerable effort from several individuals, including these selfless volunteers. We should all extend our thanks to our hosts and the technical program chairs for all of their hard work when you see them at the conference. Finally, we would like to thank the members of the Conference Coordinating Committee, Shreyes Melkote, Steve Schmid, John Ziegert, Xiaoping Yang, Brian Paul and Ihab Ragai, for their dedication and efforts to the strategic planning of these conference and future ones.

In closing, on behalf of the Conference Coordinating Committee members, we wish you a productive conference and hope you will take advantage of this international conference setting to meet old friends, make new acquaintances, and establish new collaborations. Enjoy the conference!

Hideki Kyogoku
Kinki University



Brad Kinsey
University of New Hampshire



Robert Ivester
US Department of Energy



To have friends coming in from afar, how delightful!

友あり遠方より来たるまた楽しからずや!

Wenn Freunde aus der Ferne kommen, ist das etwa kein Anlass zur Freude!

有朋自远方来, 不亦乐乎!

Confucius (551–479 BC)

Welcome from 2014 MSEC-NAMRC-ICMP Co-Hosts

Dear Colleagues,

As the co-hosts of 2014 MSEC-NAMRC-ICMP and on behalf of the manufacturing group at the University of Michigan at Ann Arbor, we welcome you to Detroit. This conference marks the first time that we, as a group of manufacturing researchers, have the opportunity to co-locate with thousands of industry participants in RAPID 2014 and BigM. It gives us the opportunity to visit exhibits and witness the state-of-the-art in additive manufacturing technology driven by advanced research and development. It also offers an excellent avenue for participants from industry to attend our academic sessions and to learn more about advanced manufacturing research and technology. We hope everyone can take advantage of this unique arrangement to forge connections between manufacturing research and industry.

We have worked closely with the Society of Manufacturing Engineers (SME) over the past two years to plan this conference. SME has provided critical and timely assistance in a truly collaborative effort to jointly organize this mega conference. Importantly, this conference comes at a critical time for renaissance of manufacturing in the United States.

In addition to the resurgence of manufacturing in the United States, the conference celebrates Prof. S.M. Wu's 90th anniversary and the 20th year since the first Wu Symposium held at Northwestern University in 1994. The Wu Symposium brings together outstanding panelists from the Manufacturing Innovation Institutes, as well as global industry and education leaders, to share exciting stories of manufacturing excellence.

We would like to thank two key staff members, Patricia Mackmiller and Kathy Bishar, who have led the preparation for this conference. We also want to thank Prof. Kon-Well Wang who encouraged and supported the hosting of this major conference, and Prof. Kornel Ehmann who provided the initial spark and push to bring the Wu Symposium back to the US. We are indebted to the NAMRI Scientific Committee, and ASME and JSME Technical Committees for overseeing the technical paper submission.

In closing, we hope this conference will help you to foster new collaborations with industry, establish friendships with colleagues around the world, and have a great and memorable time in Detroit and Ann Arbor, Michigan.

Albert Shih



Kira Barton



Chinedum Okwudire



Welcome from the 2014 MSEC-NAMRC-ICMP Technical Program Chairs

On behalf of the Technical Program Committees, we welcome you to the joint International Manufacturing Conference consisting of the ninth ASME International Manufacturing Science and Engineering Conference (**MSEC2014**), sponsored by the Manufacturing Engineering Division (MED) of ASME, the 42nd North American Manufacturing Research Conference (**NAMRC42**), sponsored by the North American Manufacturing Research Institution of the SME (NAMRI/SME), and the fifth International Conference on Materials and Processing (**ICMP2014**), sponsored by the Japan Society of Mechanical Engineers (JSME) and ASME, collocated and hosted by the University of Michigan - Ann Arbor from June 9 to June 13, 2014, in Detroit, Michigan. As leading world-class societies in the Mechanical Engineering field, ASME, SME and JSME act as global bridges between industries, government laboratories, and academic institutions. This joint conference symbolizes the continued collaboration between these esteemed organizations in research exchanges and disseminations in the Manufacturing, Materials and Processing fields.

Each of the collocated conferences includes technical sessions covering the full range of manufacturing topics. Every single paper submitted to conference was put through a rigorous peer review process. We are in debt to all reviewers for their critical assessment of a very large number of submissions.

MSEC2014 received 232 draft papers. After the rigorous peer review process 197 papers were accepted for presentation in over 70 sessions. This year, the conference has 28 symposia in 5 Technical Tracks: Materials, Processing, Micro and Nano Technologies, Properties, Applications and Systems, and Sustainable Manufacturing. In addition, 12 posters were accepted for publication in the proceedings and 1 was accepted for presentation at the conference. The conference will also host keynotes in three emerging areas: Forming and Light-Weight Materials, Additive Manufacturing, and Cloud Manufacturing. The keynote speakers are world-renowned scientists from 5 different countries.

NAMRC42 received over 90 technical papers. Following the review process, 75 papers were accepted for publication in the Proceedings of NAMRI/SME and presentation at the conference in 25 technical sessions. The papers included in the conference address a wide range of basic and applied manufacturing research topics related to both manufacturing processes and manufacturing systems.

ICMP2014 has a total of 111 presentations and 103 papers in over 35 technical sessions. This is the third joint event between MSEC and ICMP. In the initial organization of both conferences, the organizers maintained the track and symposia names the same between the two conferences to better facilitate the collocation. ICMP has abundant expertise in dealing with different conventional and emerging engineering materials such as, from an exhaustive list, metals, ceramics, various types of composites, and multi-functional as well as smart materials, etc. By bringing the three conferences together, it has shown certain contents of strong coherence, and yet other subjects being unique on its own. Hence, this conjunction will unquestionably cultivate a dynamic and stimulating environment to all the participants.

The conference program is the result of the outstanding efforts of many people. We would like to thank all the authors for their technical paper and poster submissions. We also express our gratitude to all the organizers for their dedicated management of the tracks, symposia as well as for guarding the quality of the papers and posters to be presented, which have contributed a great deal to the success of the conference technical program. We would also like to thank the

host Organizing Committee, the Conference Coordinating Committee, the NAMRI/SME Scientific Committee, and the ASME MED Executive and Technical Committees. Our thanks also go to the ASME staff for their outstanding job in presenting conference information on the Internet, managing the submitted technical papers and posters, and ensuring high-quality publication of the conference proceedings for MSEC2014, NAMRC42, and ICMP2014. We would like to extend our gratitude to all sponsors for providing financial support. Additionally, we would like to thank the Advanced Manufacturing Cluster within the Civil, Mechanical, and Manufacturing Innovation (CMMI) Division of the National Science Foundation for providing registration support for US student participants.

We wish you a productive and enjoyable conference in Detroit, Michigan. We hope that the proceedings are beneficial and we sincerely wish your long-lasting affiliation and contributions to the future MSEC NAMRC and ICMP.



Ihab Ragai
East Carolina University
2014 MSEC Technical
Program Chair



John C. Ziegert
University of North Carolina -
Charlotte NAMRI/SME Scientific
Committee Chair



Seiichi Hata
Nagoya University
2014 ICMP Technical Program
Chair



Gracious Ngaile
North Carolina State University
2014 MSEC Technical Program Vice- Chair

namri

sme



Sponsors:

AMT



ENABLING DATA-DRIVEN MANUFACTURING

www.MTConnect.org

MTConnect is an open, royalty-free, secure standard, which provides a common transport and format for all manufacturing data from devices to manufacturing intelligence systems, reducing the complexity and increasing the value that can be delivered by software applications.

What this means to you is:

- **Increased** utilization
- **Greater** profits
- **Improved** efficiency
- **Seamless** interoperability

German Research Foundation



**Forschungsvergnügen!
Discover German Engineering**

Visit the "Research in Germany" - Booth.

- Tuesday, June 10 - Thursday, June 12 (2 pm)
Networking Room 310A

Join the "Research in Germany Science Lunch".

- Thursday, June 12, 12 - 1.30 pm
Room 410AB

Advance your research career in Germany and learn about funding opportunities in engineering.



Find us on Facebook and Twitter!



[facebook.com/
Research.in.Germany](https://facebook.com/Research.in.Germany)



[twitter.com/
ResearchGermany](https://twitter.com/ResearchGermany)

**Research in
Germany**
●●●●●●●●
Land of Ideas

www.research-in-germany.de

Sponsors (cont.)

The logo for KISTLER, featuring the word "KISTLER" in a bold, blue, sans-serif font.

measure. analyze. innovate.

Kistler Instruments Corporation
Exhibit Booth in 310A on Tu, Wed, Thur



Aerotech Incorporated
Exhibit Booth in 310A on Tuesday



Ford Motor Company – Recruiting



Drexel University Online Degree



Matsuura

NANOVEA[®]
A Better Measure.

NANOVEA



Yamaha Motor Co., Ltd.



Integrative Systems + Design



Furukawa Electric Group

June 9

Monday

- | | |
|--------------------|--|
| 1:00 pm – 7:00 pm | Registration |
| 4:00 pm – 6:30 pm | MSEC-NAMRC-ICMP Welcome Reception at Room 410AB |
| 6:00 pm – 10:00 pm | SME Gala at Cobo Center Grand Riverview Ballroom |

June 10

Tuesday

7:30 am – 4:00 pm	Conference Registration
7:30 am – 8:30 am	Continental Breakfast
8:30 am – 9:30 am	Welcome and Keynote (together with Rapid and Big M)
9:30 am – 10:00 am	BREAK
10:00 am – 5:00 pm	Sponsor Exhibits: Room 310A and Cobo Center Exhibition Hall
10:00 am – 11:30 am	Parallel Sessions and Panels / Steven Malkin Symposium
11:30 am – Noon	MSEC/NAMRC/JSME Conference Welcome
Noon – 1:30 pm	Lunch: sponsored by JSME
1:30 pm – 3:00 pm	Parallel Sessions and Panels / MSEC Metal Forming and Additive Manufacturing Keynotes
3:00 pm – 3:30 pm	BREAK
3:30 pm – 5:00 pm	Parallel Sessions and Panels
5:00 pm – 8:00 pm	Early Career Forum
5:00 pm – 5:45 pm	ASME/MED Member Meeting
5:45 pm – 6:30 pm	NAMRI/SME Member Meeting
6:00 pm – 9:00 pm	Celebration of Reconfigurable Manufacturing Systems

Steve Malkin Symposium Opening Session
Tuesday, June 10, 10 am – 11:30 am, Room 310B

National Academy of Engineering Tribute
by Yoram Koren

STEPHEN MALKIN, an international guiding force in manufacturing science, and a University Distinguished Professor Emeritus at the University of Massachusetts, Amherst, died on August 19, 2013, at the age of 72.

Steve, as he was generally called, was born in Malden, Massachusetts, on June 20, 1941. In his high school Steve was an ambitious student who pushed himself to excel. No doubt that he was admitted to the Massachusetts Institute of Technology and received a bachelor's degree from MIT in 1963.



Steve liked the taste of research experience in his undergraduate studies and decided to attend graduate school at MIT, and to specialize in manufacturing engineering. He earned his M.Sc. in 1965, and in 1968 he graduated from MIT with a Sc.D. in Mechanical Engineering.

In 1968 Steve became an Assistant Professor at the University of Texas, Austin, and in 1974 he moved to the University of New York in Buffalo, where he was promoted to Associate Professor. In 1976 he immigrated to Israel where he was a professor at the Technion, Israel Institute of Technology until 1986. In 1986 Steve returned back to the U.S. and became a professor of Mechanical Engineering at the University of Massachusetts in Amherst. From 1987 until 1995 he was Director of the Manufacturing Engineering Program at U-Mass, and a co-founder of the Center for Manufacturing Productivity, which paired faculty with small to medium sized manufacturers to enhance productivity and competitiveness. He was named Distinguished Professor at the University of Massachusetts in 1998. Steve served as the Head of the Department of Mechanical and Industrial Engineering from 2000 to 2006.

Steve has done a superb job in his two terms as Department Head. He was a visionary leader, and above all, an excellent mentor to younger faculty -- as evidenced by the number of faculty who was hired/promoted and recognized nationally/internationally during his tenure. As Department Head Steve had unique style of inclusiveness and impartiality, along with his intellectual and professional rigor – as evidenced by his several new initiatives such as the Department Seminar Series, the Department Cluster Groups embracing the department's diversity and richness. Wind Energy and Human Performance programs came into international prominence during his tenure and have since been recognized as the two signature programs of the department and college. Under his leadership, the department's human and fiscal resources grew significantly. Many new faculty were hired, the enrollment increased by over 50% and research expenditures increased by 44%. He retired in 2009.

Steve Malkin authored a scholarly body of papers on grinding technology that constitutes the spearhead of innovative research in this area, and it is the leading light of new research directions in modern grinding optimization technology. He has led the transformation of grinding technology from an empirical craft to an applied science by laying the foundation for grinding system theory and developing enabling technologies to improve the system efficiency. Steve is the author of the book on Grinding Technology that presents a comprehensive and consistent

treatment of grinding theory and its practical aspects. It is amazing that this book was cited over 1000 times by other researchers.

A primary objective in his early research was to develop a fundamental understanding and quantitative models which describe the many diverse aspects of grinding including the mechanics of the process, temperatures, thermal damage to the workpiece, precision, and surface topography. He then realized that this fundamental processing knowledge could be more practically applied by taking a comprehensive systems approach in which the grinding model parameters are updated and intelligent control is utilized to optimize the process.

Steve developed virtual manufacturing that provides a quantitative and visual computerized simulation of the process to predict what will occur and to identify the optimal conditions. Malkin's simulations are being used in industry. Another approach that Steve pioneered was the coupling of the knowledge base and simulation with intelligent control methodologies to achieve adaptive optimal control of grinding machines.

Industries that utilize Steve's modeling and optimization methodologies include General Motors, Ford Motor Company, SKF, General Electric, Alcoa, Norton Company, Eaton Corp., United Technologies, Pratt and Whitney, Caterpillar, Allied Signal, The Timken Company, TRW, Warner and Swasey, Iscar Blades, and many others. Experts documented millions of dollars in savings by Steve's original grinding simulation and optimization methodology.

Steve authored 200 scientific papers, and graduated 50 students, most of which are employed in high level engineering positions and management. Steve loved his students and maintained close relationships with them.

Steve was a Life Fellow of the American Society of Mechanical Engineers (ASME), and a Fellow of the Society of Manufacturing Engineers (SME). He was a Fellow of the International Academy for Production Engineering (CIRP) since 1980. Steve received the ASME William T. Ennor Manufacturing Technology Award (ASME), the Gold Medal of SME, and the Blackall Machine Tool and Gage Award of ASME.

Steve Malkin was honored by the title Doctor Honoris Causa by the Jan Evangelists Purkyne of the Czech Republic. He was Honorary Member, Romanian Society of Mechanical Engineering, and Honorary Professor of the National Huaqiao University in China. Steve was the R.S. Springer Visiting Professor at the University of California, Berkeley. He was the Lady Davis Visiting Professor, and later the Safra Visiting Professor at the Technion – Israel Institute of Technology, Haifa, Israel. Steve continually sought opportunities to serve the community, advise, lead, and help others. He is greatly missed.

Steve is survived by his mother Jeannette, his beloved wife for 41 years Maccabit, his son Gonen and his daughter Ruth, four granddaughters: Noa, Shai, Judith and Millie, his sister Celia, a nephew and a niece.

JSME Lunch Keynote
Tuesday, June 10, 12:40 pm – 1:20 pm, Room 410AB

Advanced Powder Processing Techniques – MIM & DLF – of Titanium Alloy Powders

Hideshi Miura

Mechanical Engineering, Kyushu University, Fukuoka, Japan



Titanium and its alloys have been widely used for various industrial and medical applications because of their excellent characteristics of low density, high corrosion resistance and high biocompatibility. However, it is not easy to produce the complicated shape and precise parts with low cost because of their poor workability. Therefore the advanced powder processing techniques such as Metal Injection Molding (MIM) and Direct Laser Forming (DLF) are hoped to be a suitable technique for fabricating the complex shaped Ti alloy components. In this talk, various high performance Ti alloy materials such as Ti-6Al-4V and Ti-6Al-7Nb have been developed by MIM or DLF processes. Eventually, not only the complex shape but also the excellent properties as same as the wrought materials were achieved.

Speaker Biography Hideshi Miura is Professor of Mechanical Engineering at Kyushu University, and the President of Japan Society of Powder & Powder Metallurgy (JSPM). His BS, MS, and PhD degrees are from Kyushu University. He held the 2012 P/M World Congress at Yokohama in Japan as Vice-chairman. He published about 300 articles, 1 book (Translated the Powder Metallurgy Science written by R. M. German), 12 patents, and 20 edited books. He received more than 20 Awards from JSPM, JSME, JIM, ISIJ, etc.

MSEC Keynote: Forming and Joining
Tuesday, June 10, 1:30 pm – 3 pm, Room 310B

Extrusion of Multi-Material Components

Prof. Dr.-Ing. Dr.-Ing. E.h. A. Erman Tekkaya

Institute of Forming Technology and Lightweight Construction
TU Dortmund, Germany



Three innovative extrusion processes for the manufacture of multi-material parts are discussed: co-extrusion of discontinuously steel reinforced aluminum profiles, composite extrusion of continuously steel wire reinforced profiles and composite rod extrusion. In the first two processes the embedded steel elements are not deformable while by composite rod extrusion both materials are deformable. By means of experimental and numerical analysis, the parameters that mainly influence the reinforcement ratio, the extrusion force as well as the material distribution are analyzed. On the basis of this, analytical approaches are deduced to describe the process limits for the technologies. The paper closes with examples of applications regarding the lightweight requirements as well as functional integrations by forming multi-materials.

Speaker Biography:

- Since 2013 Vice Dean of the faculty of mechanical engineering at TU Dortmund, Germany
- Since 2007 Full Professor and Head (since 2009) of the Institute of Forming Technology and Lightweight Construction (IUL), TU Dortmund, Germany
- 2008 – 2013 Founding Director, Metal Forming Center of Excellence, Atilim University, Ankara
- 2005 – 2009 Chairman (until Feb. 2009) and Full Professor (until Dec.2009), Department of Manufacturing Engineering, ATILIM University, Ankara, Turkey
- 1986 – 2005 Assistant Professor, Associate Professor, Full Professor
Department of Mechanical Engineering, METU, Ankara, Turkey
- 1983 – 1986 Head of Department „Numerical Methods and Education”
Institute of Forming Technology, University of Stuttgart, Germany
- 1980 – 1983 Researcher,
Institute of Forming Technology, University of Stuttgart, Germany
- 1978 – 1980 Student, Research and Teaching Assistant,
Department of Mechanical Engineering, METU, Ankara, Turkey

MSEC Keynote: Additive Manufacturing
Tuesday, June 10, 1:30 – 2:30 pm, Room 140B

3D Printing of Bioactive Implant Coating and Biomimetic Scaffolding for Tissue Repair

Prof. Jerry Fuh

Mechanical Engineering, National University of Singapore

With the advance of 3D Printing (3DP) technologies in the past 20 years, bio-printing has been increasingly accepted by clinicians and academia for possible use in tissue engineering applications. But the most successful biomedical applications still lie on printing of intricate medical models for surgery planning. The designs and development of functional 3D human tissue for medical research and therapeutic applications in which organs and body parts are built using inkjet techniques are still in its infant stage. Printing of scaffolds, organs and layers of living cells onto a gel medium or sugar matrix and slowly building up to form 3D structures aiming for tissue repair is still been challenging by many clinicians and doctors and thus facing difficulties especially for new FDA-approved medical procedures. 3DP can potentially replicate or mimic the internal structures of normal tissues which play important roles in their biological functions, e.g. musculoskeletal tissues, where specific internal structures and microstructures confer important functional characteristics that allow normal functioning of the tissues to occur. 3D printing technologies applied to develop viable and prosthetic replacement tissues and implants for human clinical applications will be an exciting and new area of biomedical research and development in the next decade. In this talk, the promising bio-printing techniques based on the Drop-on-demand (DoD) and electrohydrodynamic jetting (E-jetting) aim to create more bioactive functionally-graded coating for implants and biomimetic 3D scaffolding for soft tissue repair/re-generation will be introduced. Case studies on meniscus, cartilage and tendon tissue repair will also be discussed.



Speaker Biography:

Dr. Fuh is a professor at the Department of Mechanical Engineering, National University of Singapore (NUS). He is a Fellow of SME and ASME and a PE from California, USA. He obtained his BS degree in Mechanical Engineering in 1980 from Taiwan and MS in Manufacturing in 1985 and PhD in Mechanical Engineering in 1992 all from UCLA before joined NUS in 1993. Dr. Fuh has devoted himself to the research of rapid manufacturing processes or 3D Printing (3DP) since 1995. He and his colleagues have established the NUS's RP/3DP research programme and set up an advanced 3DP laboratory through research grants and industrial collaborations. As a result of his research on selective laser melting for 3DP, 40 international-refereed papers were published related to the RP/3DP process and 15 to RP material developments together with 4 book chapters and 4 patents. A book entitled "Laser-Induced Materials and Processes for Rapid Prototyping" was published by Kluwer Academic, MA in 2001. In 2005, he received the IES Prestigious Engineering Achievement Award for the work on "Development of Rapid Prototyping Technologies for Precision and Biomedical Engineering" from the Institute of Engineers, Singapore (IES) in recognition of outstanding engineering skills which have made notable contributions to progress in engineering in Singapore. He has published over 300 technical papers in manufacturing and design, and supervised over 100 graduate students with over 50 are PhD students since joined NUS.

MSEC Keynote: Forming and Joining
Tuesday, June 10, 1:30 pm – 3 pm, Room 310B

Multiaxial Stress Tests on Lightweight Materials in Support of Material Modeling and Accurate Sheet Forming Simulations

Prof. Toshihiko Kuwabara

Division of Advanced Mechanical Systems Engineering, Institute of Engineering
Tokyo Univ. of Agriculture & Technology, Tokyo, Japan



This presentation is a review of mechanical test methods for accurately measuring the anisotropic plastic deformation behavior of metal sheets and tubes subjected to multiaxial stress states. A special attention is paid to the measurement and modeling of the anisotropic plastic deformation behavior of lightweight metals commonly used in industry and to the verification of the validity of the material models based on anisotropic yield functions for large plastic strain ranges. The effects of material models used in metal forming simulations on the improvement of the predictive accuracy of forming defects are also discussed.

Speaker Biography:

2004 – Professor, Division of Advanced Mechanical Systems Engineering, Institute of Engineering, Tokyo University of Agriculture and Technology (TUAT)/ 1992 – Associate Professor, Department of Mechanical Systems Engineering, Faculty of Engineering, TUAT/ 1989 – Lecture, Department of Mechanical Systems Engineering, Faculty of Engineering, TUAT/ 1987 – Research Associate, Laboratory of Precision Machinery and Electronics, Tokyo Institute of Technology/ 1987 – Doctor of Engineering, Interdisciplinary Graduate School of Science and Engineering, Tokyo Institute of Technology/ 2010-2013 – Adjunct professor of GIFT, POSTEC/ 2013 – Member of Education and Research Council (TUAT).

Early Career Forum: Research Professions in Academia, Industry & National Laboratories

Tuesday, June 10, 5 pm – 8 pm, Room 410AB

Organized by AMSE/MED and NAMRI/SME

Lead: Prof. Laine Mears, Clemson University

Purpose The objective of the Early Career Forum is to educate students engaged in scientific programs around manufacturing and early-career manufacturing engineers and scientists on the possible career paths available to them, and details of feasible expectations for activities and future opportunities when following a given career path. This objective will be addressed through a small-scale networking event where manufacturing students and young engineers are introduced to a panel of mid-career professionals, and placed in an environment of local discussion. The anticipated benefits of this personal engagement are a better understanding by participants of what to expect from a given career, dispelling of myths around a certain career path or position, and a path for networking (creating a contact network) for future information sharing.

- The forum will start with a 3-5 minute spoken introduction by each panelist representing academic, government, and industrial sectors. Speakers will discuss their background, career path, and area of expertise.
- Breakout round-table sessions will immediately follow, and make up the bulk of the interaction. This will let you ask questions of specific panelists, and hear further detail of their experiences and perception of a specific career path (good and bad).
- At the end, a light reception will be served, offering ample time for participants to continue conversations/discussions related to their particular/personal interests.

Fee \$5 per participant, register or pay at the door.

Panelists

Dr. Kavit Antani, BMW Manufacturing Kavit Antani is a Quality Engineer at the BMW plant in Spartanburg, SC, responsible for X5 and X6 Powertrain Assembly. Kavit received his Ph.D. from Clemson University – International Center for Automotive Research (CU-ICAR) where he was a BMW Scholar in Manufacturing from 2011 to 2014. He worked previously for DeWalt Power Tools, a professional power tools division of Stanley Black & Decker for 11 years leading cross functional Kaizen events and training in the United States, Czech Republic, China, Brazil, and Mexico before returning to graduate school to pursue a doctoral degree.

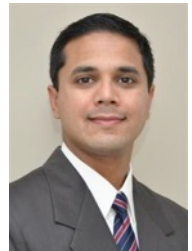

Dr. Andrea Campbell, Ford Motor Company Andrea Campbell is the leading expert on advanced mechanical joining technologies at Ford Motor Company, where she has been for 14 years. She has had a significant role in developing joining technologies for the all new F150, particularly related to joining advanced aluminum alloys. She started her career at Ford after graduating from University of California Berkeley with a doctorate degree in Materials Science and Engineering and a dissertation in fracture and fatigue behavior of shape-memory and superelastic materials.



Prof. Dragan Djurdjanovic, University of Texas at Austin Dragan Djurdjanovic worked with the Dept. of Mechanical Engineering at the University of Michigan as an Assistant Research Scientist before joining the faculty of University of Texas Cockrell School of Engineering in September 2007. His research focuses on



employing advanced mathematical modeling and control methods to problems in design, diagnostics and operation of complex systems. He is the recipient of the 2006 Outstanding Young Manufacturing Engineer Award from SME.

Dr. Robert Ivester, US Department of Energy Advanced Manufacturing Office Robert W. Ivester, Ph.D., currently serves as the Deputy Director of the Advanced Manufacturing Office in the U.S. Department of Energy under the Office of Energy Efficiency and Renewable Energy. Previously, he served as the Executive Secretary to the Inter-agency working group on Advanced Manufacturing through the office of the President. He has also been an instructor for the Johns Hopkins University Engineering for Professionals program for graduate-level studies in manufacturing engineering since 2001.

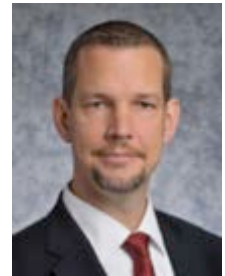

Prof. Mathew Kuttolamadom, Texas A&M University Dr. K is an Assistant Professor in the Manufacturing and Mechanical Engineering Technology program within the Dwight Look College of Engineering at Texas A&M University. His current research focus and interests are in tribology, wear modeling, machining titanium and heat-resistant alloys, and surface metrology. He is the recipient of the Outstanding Young Alumni Award in the College of Engineering & Science from Clemson University.



Dr. Shawn Moylan, NIST Shawn Moylan is a mechanical engineer and a project leader in the Engineering Laboratory at the National Institute of Standards and Technology (NIST), where he has worked on a variety of projects in manufacturing metrology, including measurement science for additive manufacturing and smart machine tools. He was the 2012 recipient of the SME Outstanding Young Manufacturing Engineer award. Shawn has successfully completed the “Building the Next Generation” leadership development program at NIST; his PhD is from Purdue.



Prof. Chinedum Okwudire, University of Michigan Dr. Chinedum Okwudire received his Ph.D. degree in Mechanical Engineering from the University of British Columbia (UBC), Vancouver in 2009; as part of his doctoral studies, he was a visiting researcher at Siemens in Germany. He joined the mechanical engineering faculty at the University of Michigan in 2011. He has worked on the design of ultra-precision machine tools, and currently performs research in improving the cost-effectiveness, energy-efficiency, accuracy and speed of precision and manufacturing machines using novel design and control methods.



Prof. Z.J. Pei, National Science Foundation Z.J. Pei received his PhD in Mechanical Engineering from University of Illinois at Urbana-Champaign. He has worked as a post-doc for a year and in industry for four years before joining Kansas State University where he is currently a professor. Since August 2012, he has been serving as the program director of the Manufacturing Machines and Equipment program at National Science Foundation. He has graduated 10 PhD and 6 MS students, and currently works with 2 PhD students.



Prof. Ihab Ragai, East Carolina University Dr. Ihab Ragai is an Assistant Professor of Mechanical Engineering at the College of Engineering and Technology at East Carolina University. Prior to joining ECU in September 2013, he was the Senior Engineering Manager of Technical Analysis and Design at Hitachi Truck in Canada. He has held several positions as Design Engineer, Project Engineer, Senior Project Engineer, and Project Manager. His areas of expertise are finite element analysis, material characterization, and simulation of manufacturing processes. He earned a Ph.D. in Mechanical Engineering from McGill University.



Dr. Michael Smith, Chrysler Corporation, LLC Michael Smith is currently an Aftertreatment Engineer for Chrysler Powertrain group. Dr. Smith's research interests involve a systems level approach to emissions control from an internal combustion engine power source. He was previously employed as a Senior Engineer at Cummins, Inc., and formerly served as a Postdoctoral Technical Fellow at the University of Michigan. He is a graduate of the US Merchant Marine Academy (BSE) and the University of Michigan (MS and PhD).

Prof. Joshua Tarbutton, University of South Carolina Dr. Joshua Tarbutton is an Assistant Professor at the University of South Carolina where he was appointed in 2012. His research is in manufacturing, mechatronics, sensor technology, metrology, signal processing, system identification, dynamics and control. He honorably served as a soldier in the United States Army Reserve from 1999-2007, where he rose to the rank of Staff Sergeant and actively led a platoon from 2003-2004, and was awarded various medals and awards. His PhD is from Clemson University in 2011 in the area of GPU accelerated automatic tool path planning for machine tools. He spent a year as an industry post-doctoral fellow at InSituTec developing precision sensing and metrology devices for the MEMS industry.



Mr. Jason Viers, Mclean-Fogg Corporation Jason Viers earned his bachelor's degree from Tennessee Technological University in 2001. He has been an SME member since 2000 and an active professional member since 2008. Viers is currently employed as a quality engineer working for Mclean Fogg Component Solutions. Previously, he held application engineering and manufacturing engineering positions. Viers' work experience has placed him in the metalforming and automated manufacturing areas. While in those environments, Viers has been fortunate to work as a team member developing patents for manufacturing processes, which earned international automotive industry awards and recognition. He is one of this year's SME Outstanding Young Manufacturing Engineer Award honorees.



Celebration of Reconfigurable Manufacturing Systems
Tuesday, June 10, 6 pm – 9 pm, Concession Area of the Cobo Grand Riverview Ballroom
[Registration required]

This celebrates the lifetime achievements of Professor Yoram Koren in reconfigurable manufacturing systems.

June 11

Wednesday

7:30 am – Noon	Conference Registration
7:30 am – 8:30 am	Continental Breakfast
8:30 am – 10:00 am	Parallel Sessions and Panels
8:30 am – 3:00 pm	Student Design Competition
10:00 am – 10:30 am	BREAK
10:00 am – 5:00 pm	Sponsor Exhibits: Room 310A and Cobo Center Exhibition Hall
10:30 am – Noon	Parallel Sessions and Panels
Noon – 1:30 pm	Lunch: M. Eugene Merchant Manufacturing Medal of ASME/SME Lecture
1:30 pm – 3:00 pm	Parallel Sessions and Panels
3:00 pm – 3:30 pm	Buses Board and Depart from Cobo Center to Ann Arbor
4:00 pm – 5:30 pm	Lab Tours at the University of Michigan College of Engineering
5:00 pm – 5:30 pm	Buses Board and Depart to Michigan Stadium
5:30 pm – 7:00 pm	Michigan Stadium Tours and Reception
6:15 pm	Conference Photo at the Center of the Field (weather permitting)
7:00 pm – 9:00 pm	Awards Banquet: Jack Roth Stadium Club, Michigan Stadium
9:00 pm – 9:30 pm	Buses Board and Depart to Cobo Center and Conference Hotels

Student Design Competition
Wednesday, June 11, 9:30 am – 3 pm Room 415B

This student design competition is designed to foster interest in manufacturing, provide the manufacturing engineering community with fresh new perspectives on design, and create a forum for students to share their new and innovative ideas. Judges for the competition are called from industry, academia, and government. We would like to congratulate all of our student manufacturing design competition finalists and welcome them to the 2014 MSEC-NAMRC-ICMP conference. We would also like to invite all conference participants to attend the presentations by these outstanding future engineers.

Lunch Keynote: M. Eugene Merchant Manufacturing Medal of ASME/SME Lecture
Wednesday, June 11, 12:40 pm – 1:20 pm Room 410AB
M. Eugene Merchant Manufacturing Medal of ASME/SME

Riding the US “Manufacturing Renaissance” Wave: How to “Hang Ten” in Doing Your Part!

Dean Bartles

Executive Director of Digital Lab for Manufacturing (DMDI), UI LABS

Dr. Dean Bartles was recently announced as the Executive Director of the newly awarded “Digital Manufacturing & Design Innovation Institute” in Chicago which was one by a large collaborative team of 23 Universities/Colleges, 41 companies, state and local government support and strong support from the city of Chicago and led by UI LABS. Prior to this new position, Dr. Bartles spent over 35 years in the defense and aerospace industry and recently announced his retirement from General Dynamics Corporation in order to assume his new position with UI LABS.





**Manufacturing Lab Tours at the University of Michigan North Campus
 Wednesday, June 11, 3 pm – 3:30 pm: Buses depart Cobo Center to Ann Arbor,
 Michigan**

During this conference, participants will have the opportunity to tour key manufacturing labs located at the North Campus of University of Michigan's College of Engineering. These labs include:

- 3D Lab features 3D printing in the University of Michigan Library
- Lurie Nanofabrication Facility
- S.M. Wu Manufacturing Research Center
- ERC for Reconfigurable Manufacturing Systems
- General Motors Collaborative Research Laboratory Advanced Vehicle Manufacturing

**Wu Mfg Research Center, ERC for Reconf Mfg Systems,
 and GM CRL on Adv Vehicle Mfg**

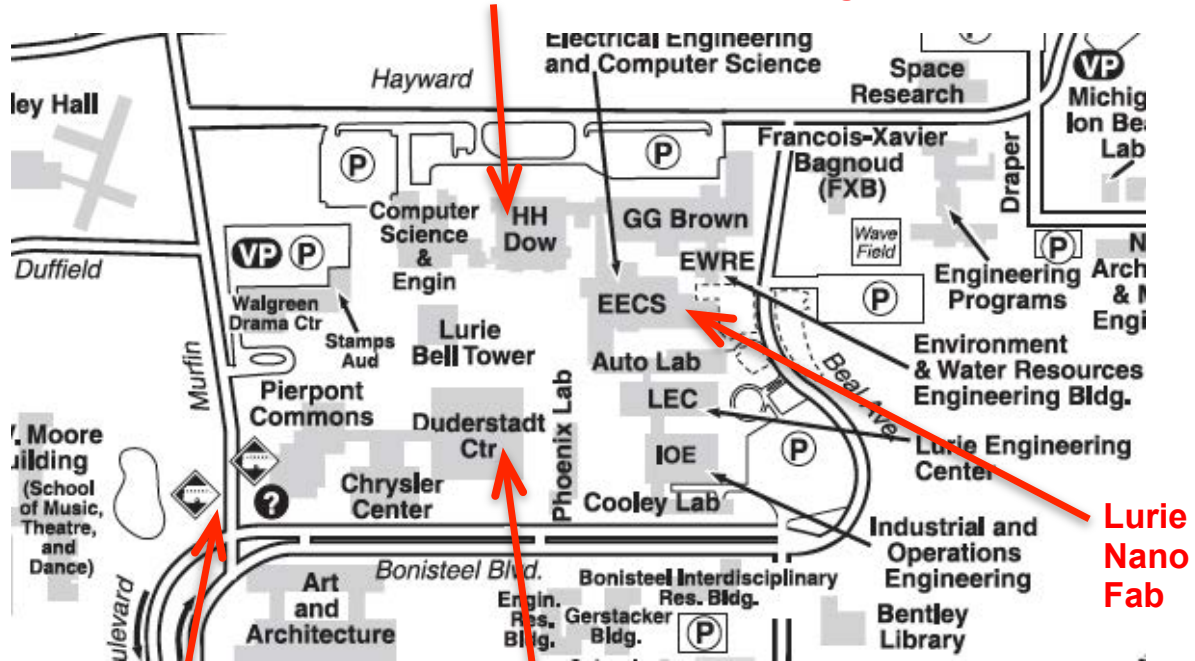

Bus loading & unloading

3D Lab

**Lurie
 Nano
 Fab**



**Awards Banquet – Jack Roth Stadium Club of the Michigan Stadium
Wednesday, June 11, 5 pm – 5:30 pm: Buses depart North Campus of University of
Michigan to Michigan Stadium**

Michigan Stadium, nicknamed "The Big House", is the football stadium for the University of Michigan at Ann Arbor. Michigan Stadium is the largest stadium in the United States, the third largest stadium in the world. The official capacity is 109,901. The last football game not sold out at Michigan Stadium was dated to Oct. 25, 1975. On football Saturdays, the stadium often held more people than the population of the city of Ann Arbor. The award banquet will be held at the Jack Roth Stadium Club. Following a guided tour of the team locker rooms and an opportunity to "take the field" under the guidance of Professor and Coach Tony Schmitz, participants will take the conference picture in the middle of the field and move into the Jack Roth Stadium Club for a brief reception and then the awards dinner.



June 12

Thursday

7:30 am – 4:00 pm	Registration: Wu Symposium on Manufacturing Competitiveness
7:30 am – 8:30 am	Continental Breakfast
8:30 am – 10:00 am	Panel with Leaders of Manufacturing Innovation Institutes Wu Symposium Session I: Emerging Advanced Manufacturing Technologies in the U.S.
10:00 am – 10:30 am	BREAK
10:00 am – 2:00 pm	Sponsor Exhibits: Room 310A and Cobo Center Exhibition Hall
10:30 am – Noon	Parallel Sessions and Panels Wu Symposium Session II: International Emerging Advanced Manufacturing Technologies
Noon – 1:30 pm	Lunch: Sponsored by ASME, AMT, and German Research Foundation
1:30 pm – 3:00 pm	Poster Sessions Parallel Sessions and Panels Wu Symposium Session III: Manufacturing Competitiveness
3:00 pm – 3:30 pm	BREAK
3:30 pm – 5:00 pm	Parallel Sessions and Panels Cloud Manufacturing Panel Wu Symposium Session IV: Education and Workforce Development

Panel with Leaders of Manufacturing Innovation Institutes
Thursday, June 12, 8:30 – 10 am, M|Exchange at Cobo Exhibition Hall

Alan Taub (University of Michigan): American Lightweight Materials Manufacturing Innovation Institute

Dennis Kekas (North Carolina State University): Next Generation Power Electronics Innovation Institute

William King (University of Illinois): Digital Manufacturing and Design Innovation Institute
Edward Morris (National Center for Defense Manufacturing and Machining, NCDMM): America Makes – National Additive Manufacturing Innovation Institute

Moderator: Prof. Thomas Kurfess (Georgia Tech), co-lead of AMP2.0 NNMI working group

Alan Taub Alan Taub joined the faculty of Materials Science and Engineering at the University of Michigan in the Fall of 2012. In this role, Taub is conducting research in advanced materials and processing and leading a new initiative to establish an Advanced Manufacturing Center within the College of Engineering. Taub retired from General Motors in April 2012. Prior to his retirement, he was vice president, Global Research & Development, leading GM's advanced technical work activity, seven science laboratories around the world, and seven global science offices. He joined GM R&D as executive director in 2001 and was named vice president in 2009. Taub serves on the boards of several small companies: Nine Sigma, CellEra and Brightway Vision and is technical advisor for a new strategic venture fund, Auto Tech Ventures. Before joining GM, Taub spent 15 years in research and development at General Electric, where he earned 26 patents and authored more than 60 papers. He also worked at Ford Motor Company for eight years. Taub received his bachelor's degree in materials engineering from Brown University and master's and Ph.D. degrees in applied physics from Harvard University. Taub was elected to membership in the National Academy of Engineering in 2006. He is currently Chair for the Visiting Committee on Advanced Technology (VCAT) for the National Institute of Standards and Technology (NIST) and is a member of The Minerals, Metals & Materials Society (TMS) Energy Materials Blue Ribbon Panel. He also serves on advisory boards for the Massachusetts Institute of Technology, Northwestern University, and the University of California, Berkeley. Taub received the 2011 Acta Materialia Materials & Society Award. In 2010, he was awarded the Charles S. Barrett Medal from ASM International's Rocky Mountain Chapter. He received the Materials Research Society's Special Recognition Award in 2004 and Woody White Service Award in 2002. He also received the Brown University Engineering Alumni Medal in 2002.



Dennis Kekas Dennis is an Associate Vice Chancellor at NC State University responsible for industry alliances, partnerships and economic development including the Centennial Campus Partnership office. He also directs NC State's Institute for Next Generation IT Systems. In addition, Dennis is currently the Interim Executive Director of PowerAmerica, the Next Generation Power Electronics Manufacturing Innovation Institute. PowerAmerica will work to make wide bandgap (WBG) semiconductor technologies cost-competitive with silicon-based power electronics, and bring together many of the



world's leading WBG semiconductor manufacturers, material providers and end-users with experts from top research universities and government agencies not only to reduce the cost, but also improve the performance and reliability of WBG devices and systems. As a former IBM executive, Dennis developed many disruptive products including optical scanners, point-of-sale systems, access products, servers and other systems. He is a co-founder of ImagineOptix, a start-up commercializing optical technologies from NC State, and serves on several advisory boards. He received his BSEE from Clemson with graduate studies at Syracuse and NC State, and UCLA's Modern Engineering program. A Professional Engineer in New York and North Carolina, he has been awarded 8 patents, as well as IBM awards for outstanding inventions, technical achievements and management excellence. Previously he was president of the Clemson Alumni Association and in 1999 received the association's Distinguished Service Award. He currently serves on the board of the Clemson University Research Foundation.

Edward Morris Operated by the National Center for Defense Manufacturing and Machining (NCDMM), America Makes – National Additive Manufacturing Innovation Institute serves as a nationally recognized additive manufacturing center of innovation excellence. Under Ed's leadership, America Makes is focused on accelerating the adoption of additive manufacturing design and production technologies in the U.S. by bridging the gap between basic research and technology development and deployment. Previously Mr. Morris was the Director of Mechanical Engineering & Manufacturing on the Lockheed Martin Corporate Engineering & Technology team. Mr. Morris is an active member of the National Defense Industrial Association's Manufacturing Division. He represents industry on the DoD ManTech Program Strategic Planning Working Group and the Joint Defense Manufacturing Technology Panel's Electronics Subpanel and Advanced Manufacturing Engineering Subpanel. He is also a member of the National Academies' National Materials and Manufacturing Board. Mr. Morris has a Bachelor of Science in Aeronautical Engineering from Purdue University and an MBA from the University of Texas at Arlington. In 2013 he received the Outstanding Aerospace Engineer Award from Purdue University's School of Aeronautics and Astronautics.



William King William P. King, Ph.D. is the Chief Technology Officer at the Digital Manufacturing and Design Innovation Institute in Chicago, IL. Dr. King is also the College of Engineering Bliss Professor at the University of Illinois Urbana-Champaign. Dr. King received a Ph.D. from Stanford University and completed the Program for Leadership Development at Harvard Business School. At the University of Illinois, Dr. King leads a research group whose work crosses boundaries between science, technology, and business. Dr. King has been founder, advisor, or director at a dozen early stage technology companies with a focus on nanotechnology, materials, and manufacturing. He is the winner of numerous awards including the PECASE award from the White House and the ASME Gustus-Larson Award for accomplishment in Mechanical Engineering. He was named by Technology Review Magazine as a person whose innovations will change the world. He has published more than 180 journal articles, and is a Fellow of ASME and AAAS.



The **American Lightweight Materials Manufacturing Innovation Institute (ALMMII)** is a public-private partnership that will develop and deploy advanced lightweight materials manufacturing technologies, and implement education and training programs to prepare the workforce.

Lightweight materials are increasingly important to the competitiveness of transportation manufacturing sectors, including suppliers in the automobile, aircraft, heavy truck, ship, rail, and defense manufacturing industries. Lighter vehicles for the military, industry, and consumers alike, have better performance and use less fuel. They can carry larger loads and travel the same distances at lower cost and with fewer carbon emissions.

ALMMII was selected through a competitive process led by the **US Department of Defense** under the **Lightweight and Modern Metals Manufacturing Innovation (LM3I)** solicitation issued by the U.S. Navy's Office of Naval Research.

ALMMII's mission is to serve US manufacturing by supporting innovative manufacturing technologies, and enable cost effective lightweighting of components for the aerospace, automotive, defense, rail, and over-the-road truck industries. The institute's efforts will encompass the entire transportation supply chain, nurturing innovations from conception through design, development, and production.

ALMMII is led by Ohio-based manufacturing technology non-profit **EWI**, **University of Michigan**, and **The Ohio State University**. Its main office will be in southeastern Michigan with significant activities in Columbus, Ohio.

In addition to ALMMII's three lead founders, more than **50 other companies, universities, non-profit research institutions, and workforce development intermediaries** from around the country will be involved in this public-private partnership. ALMMII is seeking additional small, medium, and large companies to become members of the institute.

The Institute is the newest addition to the **National Network of Manufacturing Innovation (NNMI)**, a White House initiative founded to help US manufacturers employ leading-edge technology to become more competitive.

The DOD award for the Institute is **\$70 million** in federal funding to be distributed over five years, matched by at least **\$78 million** from the consortium partners themselves. Cost share commitments came from industry, state and local governments, universities, and non-profits.

ALMMII is an independent non-profit incorporated in the state of Michigan. ALMMII is a lean organization which will maximize the value delivered by leveraging and integrating existing assets in its research and workforce partner facilities.

The ALMMII region includes 5 states: Michigan, Ohio, Indiana, Kentucky, and Tennessee. However, ALMMII integrates partners nationwide for research and workforce development, including those located in Illinois, Colorado, Texas, Massachusetts, and Pennsylvania.

ALMMII's scope will include:

- Contracting more than **\$100 million in R&D projects** with partner organizations throughout the country to nurture innovations from concept through design, development, and production.
- Establishing science, technology, and engineering curricula for **programs to educate the next generation** of manufacturing operators and engineers.
- Enabling up to **10,000 new jobs** in metal stamping, metalworking, machining, and casting.

ALMMII will open under the direction of **Lawrence Brown**, Executive Director; **Alan Taub**, Chief Technology Officer; **Dan Kramer**, Chief Innovation and Transition Officer; and **Emily DeRocco**, Workforce Director.

POWERAMERICA, the Next Generation Power Electronics Manufacturing Innovation Institute, is **working to dramatically accelerate the commercialization of wide bandgap power electronics to power America**. Power electronics are important components of consumer electronic devices like phones, computers, and televisions, but are also used in larger scale applications such as industrial motor systems and electricity conversion and transmission. Great efficiencies will be achieved by replacing the silicon-based power electronics used today with those based on gallium nitride and silicon carbide, which are wide bandgap (WBG) semiconductors. **POWERAMERICA**'s mission is to create a national innovation ecosystem that facilitates workforce development, targeted research, cost reduction, domestic manufacturing, product commercialization, and market penetration of wide bandgap power electronics technologies.

The Institute **will bring many of the world's leading WBG semiconductor manufacturers, material providers and end-users together with experts from top research universities and government agencies** not only to reduce the cost, but also improve the performance and reliability of WBG devices and systems. **POWERAMERICA** will:

- develop critical WBG power electronics technologies;
- spark early commercialization in high value markets by stimulating demand;
- support and grow the manufacturing base; and
- nurture the U.S. WBG semiconductor industry through education programs and training.

The Institute's \$146 million effort is **funded by a \$70 million cooperative agreement with the U.S. Dept. of Energy, \$60 million from industry partners, and \$16 million from the State of North Carolina and its university system**. The consortium of industry, government and academic partners are united by a common vision to create sustained economic and environmental benefits to the nation.

POWERAMERICA is the second member of the National Network for Manufacturing Innovation, an initiative to address the loss of good manufacturing jobs and exports, which are seen by many as an important factor in slowing domestic economic growth.

POWERAMERICA industry partners to date are, II-VI, Inc., ABB, Inc., APEI, Inc., Avogy, Inc., Cree, Inc., Delphi, LLC, Delta, DfR Solutions, LLC, Gridbridge, Inc., IQE, LLC, John Deere Electronic Solutions, Monolith Semiconductor, Inc., RF Micro Devices, Inc., Transphorm, Inc., Toshiba International, USCi, Inc., Vacon, Inc., X-Fab Texas, Inc.

POWERAMERICA universities and lab partners are, NC State University (Lead), Arizona State University, Florida State University, University of California at Santa Barbara, Virginia Polytechnic Institute, Naval Research Laboratory, and National Renewable Energy Laboratory.



America Makes

America Makes – The National Additive Manufacturing Innovation Institute

Who are we? America Makes is the National Additive Manufacturing Innovation Institute, the national accelerator for additive manufacturing and 3D printing. 3D printing allows for production of never-before-possible products and for producing many existing products more quickly and cheaply. The vision for America Makes is to accelerate additive manufacturing innovation to enable widespread adoption by bridging the gap between basic research and technology commercialization. As a public-private partnership, America Makes fosters game-changing collaboration between multiple government agencies and over 95 companies, universities, community colleges, and non-profit organizations. In addition to technology development and commercialization, the core mission includes engaging with small and medium-sized businesses, fostering education initiatives, and conducting STEM outreach to both stimulate job creation and train a highly skilled workforce. America Makes is operated by the National Center for Defense Manufacturing and Machining (NCDMM).

Why do we exist? America Makes exists as a public-private partnership because a combined public and private investment is the most efficient and effective method to enable U.S. federal agencies, industry, and academic institutions to collaborate and coordinate. Without this joint public and private collaboration and pooling of resources, U.S. companies may suffer tremendous technological disadvantages against global competitors that are receiving significant public investments from their governments. To help the U.S. stay competitive, America Makes is creating both face-to-face and online mechanisms for broad-based collaborative efforts to identify capability gaps, solve shared problems, coordinate investments, and share knowledge in 3D printing. With the assistance of a near-term public investment, America Makes is establishing an industry culture of collaboration that will develop into a self-sustaining engine for innovation. The innovation engine will sustain itself by becoming the nation's leading organization for conducting contracted projects in additive manufacturing research and technology commercialization.

What have we accomplished? Since being launched 18 months ago, America Makes – the National Additive Manufacturing Innovation Institute has taken long strides in achieving its mission.

- Established the America Makes Innovation Factory in Youngstown, OH with over 20 additive manufacturing machines entrusted by members, plus collaboration & education workspaces.
- Engaged 95 dues-paying members from industry, academia, and non-profit organizations.
- Developed an industry-driven technology investment strategy leading to 22 ongoing applied research projects performed by 90 organizations with \$13.5M public investment and \$15M industry cost share. Initiated several agency-directed research projects funded at over \$7M.
- Began design and implementation of a website including a secure, virtual collaboration section for America Makes members which will link to a repository for materials and processing data which is central to companies being able to design new products to be produced using additive manufacturing.
- Led and supported numerous workforce training and STEM outreach programs, including an Additive Manufacturing Certificate program, providing mentoring and equipment to FIRST Robotics teams, and co-creating the privately-funded “3D Printer in Every School” initiative.



WHAT IS THE DMDI INSTITUTE?

Chicago-based UI LABS was awarded \$70 million from the U.S. Department of Defense (DoD) to fund the Digital Manufacturing Design Innovation Institute (DMDII). This award is leveraged by commitments of approximately \$250 million from industry, academic, government and community partners.

The DMDII is the nation's flagship research institute for applying cutting-edge digital technologies to reduce the time and cost of manufacturing, strengthen the capabilities of the U.S. supply chain, and reduce acquisition costs for DoD. The DMDII will both develop and demonstrate digital manufacturing technologies and deploy and commercialize these technologies across key manufacturing industries.

Digital manufacturing is the use of an integrated, computer-based system comprised of simulation, three-dimensional (3D) visualization, analytics and various collaboration tools to create product and manufacturing process definitions simultaneously. Design innovation is the ability to apply these technologies, tools and products to re-imagine the entire manufacturing process from end to end. The headquarters of the DMDII will be housed in Chicago at the Digital Lab for Manufacturing, located on Goose Island.

DMDII PARTNERS

UI LABS brought together more than 40 industry partners, and 30+ academic, government and community partners, and an additional 500+ supporting companies and organizations to launch the DMDII. Founding industry partners include General Electric, Rolls-Royce, Procter & Gamble, Dow, Lockheed Martin, Siemens, Boeing, Deere, Caterpillar, Microsoft, Illinois Tool Works, and PARC, among many others. University and government partners are regionally anchored in the Midwest, spanning Illinois, Indiana, Iowa, Wisconsin, Kentucky, Michigan, Minnesota, Missouri, and Nebraska, and extending to Colorado, New York, Oregon and Texas, to leverage the best research and technology in the country and deploy solutions on a broad scale.

DMDI INSTITUTE LEADERSHIP

The DMDII is led by Executive Director, Dean Bartles, Ph.D., who has 35 years of successful manufacturing operations, program management, marketing, and R&D experience at leading U.S. defense firms. Dr. Bartles has spent the past 13 years as vice president at General Dynamics - Ordnance and Tactical Systems. DMDII's chief technology officer, William King, Ph.D., is a globally recognized leader in manufacturing and design innovation. Dr. King is the College of Engineering Bliss Professor at the University of Illinois Urbana-Champaign, where he leads a research group whose work crosses boundaries between science, technology, and commercialization. Dr. King has been founder, advisor, or director at a dozen early stage technology companies with a focus on manufacturing, materials, and nanotechnology.

ABOUT UI LABS

As a Chicago-based research and commercialization collaborative, UI LABS brings industries, universities and government together to apply real solutions to tomorrow's most important business, economic, and cultural challenges. UI LABS actively cultivates and channels talent and resources, fosters unbiased collaboration to bring new ideas to market, and drives economic growth and competitiveness. The DMDI Institute is the first program in the UI LABS portfolio.

To learn more or become a partner of the DMDI Institute, please contact manufacturing@uilabs.org or visit <http://digitallab.uilabs.org/>.

Wu Symposium on Manufacturing Competitiveness: US Venue
Organizer: Prof. Jun Ni, University of Michigan

The Wu Symposium on Manufacturing Competitiveness (WSMC) is a one-day high-level forum on manufacturing competitiveness with sessions focusing on:

- Emerging Advanced Manufacturing Technologies in the U.S.
- International Emerging Advanced Manufacturing Technologies
- Manufacturing Competitiveness
- Education and Workforce Development

The Wu Symposium will address major challenges to the field of future advanced manufacturing and will discuss potential solutions to these challenges. WSMC generates key recommendations and provides an excellent network opportunity among government policymakers, corporate executives, entrepreneurs, and academic and social-thought leaders. WSMC will not be like a typical conference, where results from individual research projects are presented. It will not emphasize the volume of papers; rather, the value of the summary reports from various invited presentations and panel discussions will be discussed.

Plenary Session I, Emerging Advanced Manufacturing Technologies in the U.S.
Co-located with Panel with Leaders of Manufacturing Innovation Institutes
Thursday, June 12, 8:30 am – 10 am, M|Exchange Cobo Exhibition Hall

Plenary Session II, International Emerging Advanced Manufacturing Technologies
Thursday, June 12, 10:30 am – noon, Room 310B

- Ning He, Dean, School of Mechanical Engineering, Nanjing University of Aeronautics and Astronautics, China, “Emerging Advanced Manufacturing Research from China”
- Hoda ElMagargy, Director of Intelligent Manufacturing Systems, University of Windsor, Canada, “Innovations in Manufacturing Research”
- Hidemitsu Furukawa, Professor & Lab Chief of Soft & Wet matter Engineering Lab (SWEL), Yamagata University, Japan
- Erman Tekkaya, Professor, Technical University of Dortmund, Germany

Plenary Session III, Manufacturing Competitiveness
Thursday, June 12, 1:30 pm – 3 pm, Room 320

- Craig Giffi, Vice Chairman and US Leader, Consumer and Industrial Products, Deloitte, “Insights from 2013 Global Manufacturing Competitiveness Study”
- Michael Molnar, Chief Manufacturing Officer, NIST, Department of Commerce, USA
- Gary Cowger, Former Group Vice President for Global Manufacturing and Labor Relations, General Motors
- Jennifer McNelly, President, Manufacturing Institute, USA

Plenary Session IV, Education and Workforce Development
Thursday, June 12 3:30 pm – 5 pm, Room 320

- Kornel Ehmann, Professor, Northwestern University
- Shiv Kapoor, Professor, University of Illinois at Urbana-Champaign
- Albert Shih, Professor, University of Michigan
- John Sutherland, Professor, Purdue University
- Shreyes Melkote, Professor, Georgia Institute of Technology

Introduction of AMT – The Association For Manufacturing Technology
Thursday, June 12 12:25 pm - 12:30 pm
Hilena Hailu, AMT Manufacturing Technology Project Manager

Panel: Research in German
Thursday, June 12 12:30 pm – 1:20 pm

Prof. Dr.-Ing. Dr.-Ing. E.h. A. Erman Tekkaya, TU Dortmund, Germany
(Bio in MSEC Keynote: Forming and Joining on Tuesday 1:30 pm – 3 pm)

Professor Dr.-Ing. Barbara S. Linke , University of California Davis

2002 Diploma in Mechanical Engineering, specialization in production engineering, RWTH Aachen University, Germany
2007 Doctorate in Mechanical Engineering, RWTH Aachen University
2002 – 2010 Research associate at the Laboratory for Machine Tools and Production Engineering (WZL) at the RWTH Aachen University, Prof. Fritz Klocke`s Chair of Manufacturing Technology
2010 – 2012 Postdoc researcher at Prof. David Dornfeld`s Laboratory for Manufacturing and Sustainability (LMAS) at the University of California Berkeley
2012 – Now Assistant Professor at the University of California Davis



Dipl.-Ing. Florestan Schindler, Laboratory for Machine Tools and Production Engineering (WZL) at the RWTH Aachen University

2009 Diploma in Mechanical Engineering, Specialization in Production Engineering, RWTH Aachen University, Germany
2009 – Now: Research Associate at the Laboratory for Machine Tools and Production Engineering (WZL) of RWTH Aachen University, Prof. Fritz Klocke`s Chair of Manufacturing Technology



Funding programs of DFG for engineering research

Dr.-Ing. Ferdinand Hollmann, Program Director, Engineering, German Research Foundation DFG, Bonn, Germany

1992 – present: German Research Foundation DFG, Bonn, Germany
1992: Doctorate in Mechanical Engineering, RWTH Aachen University, Germany
1987 – 1992: Research associate at the Laboratory for Machine Tools and Production Engineering (WZL) at the RWTH Aachen University, Prof. Tilo Pfeifer`s Chair of Metrology and Quality Management
1987: Diploma in Mechanical Engineering, specialization in production engineering, RWTH Aachen University, Germany



Moderator:

Dr. Annette Doll-Sellen, Director, German Research Foundation DFG, New York Office

Annette Doll-Sellen completed her PhD in German literature at the University of Cologne and – subsequently – focused her attention on research administration. She gained substantial experience in international science management during her seven years in Bruxelles, where she held several executive positions. For five years she was entrusted with the directorship of

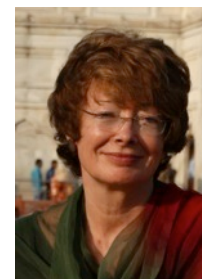

the “European Liaison Office of the German Research Organizations” and served afterwards as a senior expert for the European Commission in the Directorate-General for Research and Innovation. Upon her return to Germany Ms. Doll-Sellen took up a position as chair of the National Contact Point in Germany where she – from 2006 through 2013 concentrated her activities on the European Research Council. In the course of the “German Excellence Initiative” she was called to avail her expertise at the DFG Headquarters in Bonn for a team handling funding and management of centers of excellence throughout the country.

Poster Session

Thursday, June 12, 1:30 pm – 5 pm, Room 310A

Poster will be displayed at the wall around Room 310A. Poster spaces will be assigned by number. Presenters can put up posters in 310A starting from Tuesday, June 10. Thumbtacks or pins will be provided. Authors must stand with their poster from 1:30-5:00 pm. You will remove posters at 5:00 pm. Posters may have dimensions less than or equal to 48 inches x 48 inches (122 cm x 122 cm). You may want to bring additional literature to post under your poster.

Panel: Cloud Manufacturing

Thursday, June 12, 3:30 pm – 5 pm, Room 310B

Moderators: Prof. Lihui Wang (KTH Royal Institute of Technology, Sweden) and Prof. Xun Xu (University of Auckland, New Zealand)

Martin Helguson, Senior Project Leader, Sandvik, Sweden Dr. Martin Helguson holds a PhD from Linköping University, Institute of Technology, Sweden. His main fields of interest are related to technical product models, CAD/CAM, metrology, knowledge integration, closed loop systems and functional products. He joined Sandvik Coromant in 1998 and has had different positions e.g. as Project leader within R&D, Manager of CAD/CAM/CAE-development and integration, and Process-CIO within product development and production. He has been engaged in several internal research and development activities related to method development, process development and functional products, as well as in external national and European research projects. He is currently a Sr. Project Leader and Technology Leader within the field of intelligent machining at the Department of Business and Application Development, Intelligent Machining.



Hans-Ulrich Heidbrink, Consultant, InConTec, Germany Hans-Ulrich Heidbrink holds an electrical engineering diploma from the University of Applied Sciences in Nuremberg and is co-founder and shareholder of InConTec GmbH an ICT Research and Innovation Company. Prior to that he held several top positions within Mentor Graphics Corp. which had acquired “DESCON Informationssysteme GmbH”, one of both companies which he had funded before and managed as president. This company had established PLM, CIS and CAD library management systems. He was also Co-Founder and senior Vice President Field Operations of INCASES Engineering GmbH a CAD and EMI simulation company a successor for the EDA products of Computervision, He started his engineering career in industrial process automation and computing departments of BBC/ABB and got assigned as product manager for the first graphical process control systems. From there he changed in the CAD/CAM market at the design system pioneer Computervision Corp. His CAD/CAM experience is reached in positions in sales, marketing and international management in this company. Amongst other standardisation activities he was chairman for ECAD-MCAD collaboration at the ProStep iViP association. He holds a chair in the industrial advisory board of the Luleå University’s Faste Laboratory for Functional Product Design methods and collaboration.



Peter Everitt, Managing Director, PowerKut Group An apprentice trained engineer with a specialist background in cutting metals and rock, Mr. Peter Everitt has developed skills in cutting tool, and fixture design and manufacture, programming in 3 languages including macro B. At an advanced stage in his manufacturing career Peter decided to pursue his entrepreneurial ambition and recognized the need to understand business more fully and so enrolled on a Btec HNC in management studies where he relieved the Reinshagen UK management studies prize for best HNC student. Peter followed this with a Chartered Management Institute Post Graduate Diploma in management. In 2002 he incorporated PowerKut Limited, supplying my own design of mining cutter for cutting hard rock on Joy continuous mining machines. Under his leadership Powerkut has since grown to being a small group employing 30 people, having some of the most advanced CNC turning, Milling and Grinding, supplying high gauges, metrology equipment, machined parts and assemblies and ISO17025 (NIST) calibration and inspection to sub-micron level.



June 13

Friday

8:30 am – Noon	Sponsor Exhibits: Room 310A
8:30 am – 10:00 am	Parallel Sessions NSF Information Session
10:00 am – 10:30 am	BREAK
10:30 am – Noon	Parallel Sessions
Noon – 1:00 pm	Box Lunch Pickup

NSF Information Session
Friday, June 13, 8:30 am – 10 am, Room 310B

At this NSF information session, brief introduction to NSF, the Civil, Mechanical, and Manufacturing Innovation (CMMI) Division, the Manufacturing Cluster, and the Manufacturing Machines and Equipment (MME) Program will be given; what's new in CMMI will be provided; and portfolio analysis of the MME program will be discussed. The rest of the session will be devoted to Q&As.

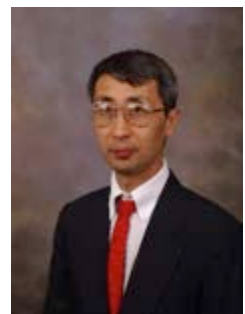

Volunteers



Margaux Balagna



Barry Belmont



Lei Chen



Dr. Roland Chen



Molong Duan

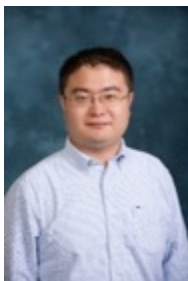

Xi Gu

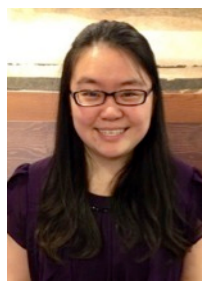

Weihong Guo



Kazuma Kato

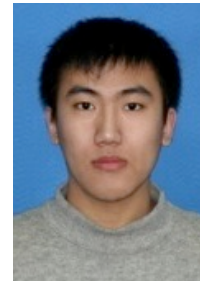

Weisi Li

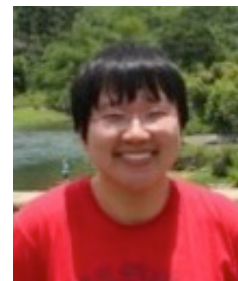

Xun Liu



Yangbing Lou



Ying Luo

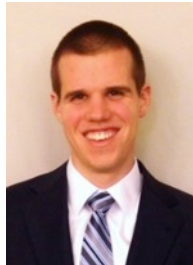

Jeffrey Plott

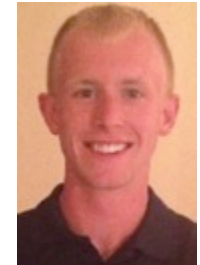

Nicholas Putman



Naoaki Saeki



Miguel Saez



Huanyi Shui



Dr. Bruce Tai



Leo Tse



Deokkyun Yoon



Zhifen Zhang

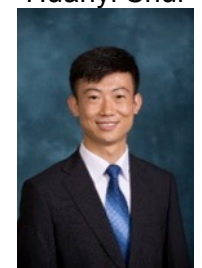

Yihao Zheng

Map of Cobo Center Presentation Rooms

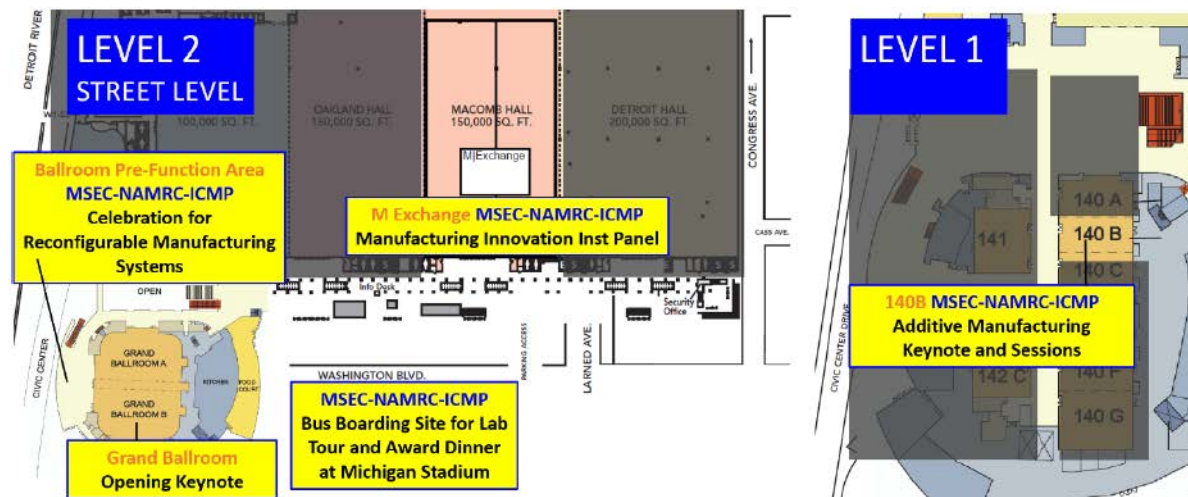
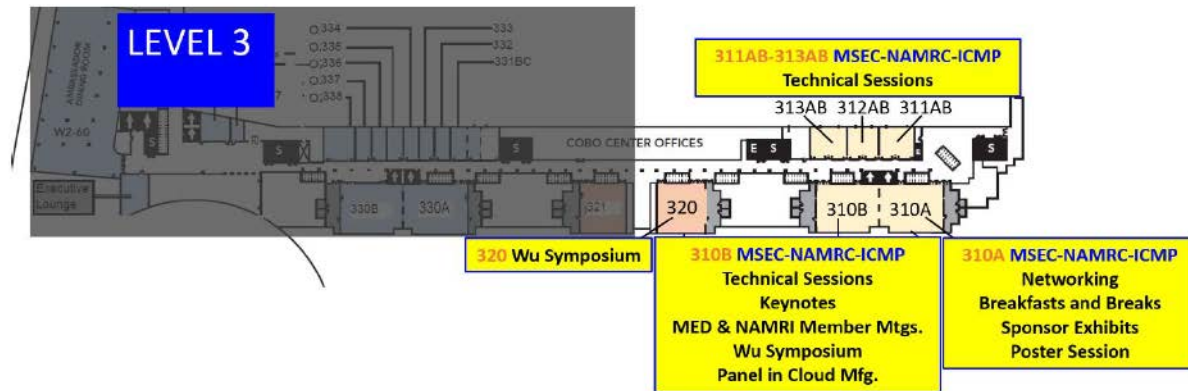
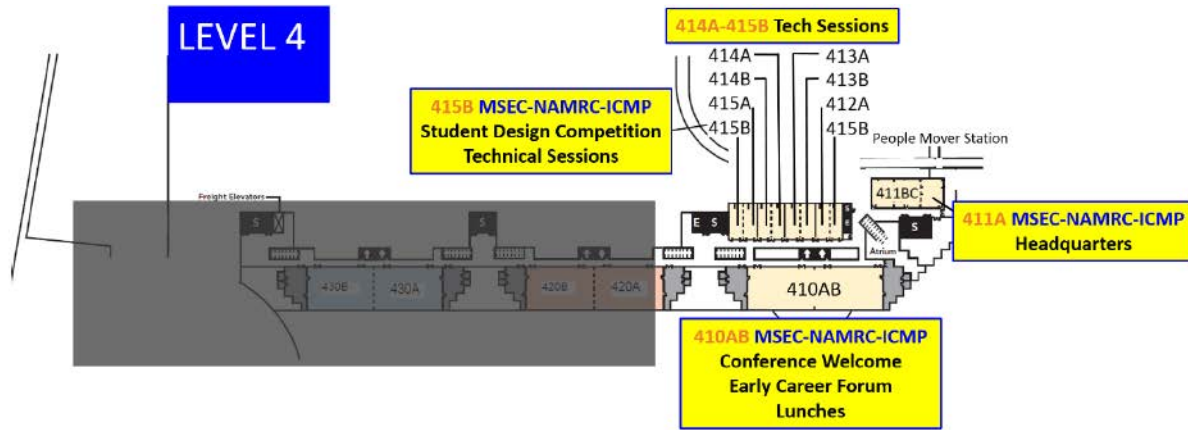

Map Detroit Downtown and People Mover Route and Stations



Cobo Parking Map



DIRECTIONS TO COBO CENTER

- **From North**
Southbound on the Lodge US-10, exit Larned St. (on left); right on Washington Blvd.
Southbound on I-75 take I-375 to Jefferson Ave. west to Washington Blvd.
- **From South**
Northbound on I-75, exit Lodge US-10 to Larned St. (on left); right on Washington Blvd.
- **From East**
Westbound on I-94 to I-75 south; take I-375 to Jefferson Ave. west to Washington Blvd.
- **From West**
Eastbound on I-96 or I-94, take the Lodge US-10 south; exit Larned St. (on left); right on Washington Blvd.
- **From Canada**
Tunnel crossing: left on Jefferson Ave. west to Washington Blvd.
Ambassador Bridge crossing: take I-75 northbound to the Lodge US-10 south; exit Larned St. (left side); right on Washington Blvd.

COBO CENTER PARKING

- 1 **Cobo Rooftop Parking**
From front of Cobo Center, go north to Congress St. Turn left, stay in right lane to circular ramp between Second and Third Streets.
From the Lodge US-10 south, take the Howard St. exit to Fort St. Left on Fort one block and turn right on Third St. Proceed to circular ramp to roof parking.
- 2 **Cobo Center Congress Street Garage**
Cobo Center Congress Street Garage is located at Congress and First Streets under Cobo Center.
- 3 **Cobo Center Washington Blvd. Garage**
Cobo Center Garage is located at the intersection of Jefferson and Washington Blvd. in front of the main entrance to Cobo Center.

June 8-12, 2015
Charlotte, North Carolina

Be a part of the next
Innovations in Manufacturing!

Be a leader in manufacturing research as a presenter of your cutting-edge discovery or by attending this exclusive conference and experiencing first-hand what's on the manufacturing horizon.

The co-location of ASME's MSEC 2015 and SME's NAMRC 43 creates the premier international forum for manufacturing research and development and applied research and industrial applications in manufacturing and design.

Visit namrc-msec-2015.uncc.edu to learn more or call 800-433-4763.



International Manufacturing Research Conference 2015

Hosted by:



Sponsored by:

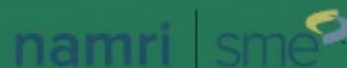

North American Manufacturing
Research Institution of SME